

A^{RF29} Transceivers modules



User Guide

No part of this document may be reproduced or transmitted (in electronic or paper version, photocopy) without Adeunis RF consent.

This document is subject to change without notice.

All trademarks mentioned in this guide are the property of their respective owner.

ADEUNIS RF

283, rue Louis Néel

38920 Crolles

France

Phone +33 (0)4 76 92 07 77

Fax +33 (0)4 76 08 97 46

Ref. 07-02-V4-smn

Table of Contents

About this Document	2
Presentation.....	4
User's interface	4
Power supply	5
Standby	6
Transmit/Receive mode selection	6
Data to transmit / data received	6
Bit encoding.....	8
Frame encoding	8
Channel selection	9
Transmitted power selection	9
BUSY output	10
Channel settling time (Cst).....	12
RSSI output	12
Recommandations for use	13
Dimensions	14
Compliance with regulations	15
Specifications.....	16

About this Document

This guide describes the A^{RF29} devices, their options and accessories.

Declaration of Conformity



Manufacturer's name: **ADEUNIS R.F.**
 Manufacturer's address: Parc Technologique PRE ROUX IV
 283 rue Louis NEEL
 38920 CROLLES - FRANCE

declares that the product if used and installed according to the user guide available on our web site www.adeunis-rf.com

Product Name: **ARF29**
 Product Number(s): **ARF6921G / ARF6921H**
 is designed to comply with the RTTE Directive 99/5/EC:
 EMC: according to the harmonized standard EN 301 489.
 Safety: according to the standard EN 60950-1/2001
 Radio: according to harmonized standard EN 300-220 covering essential radio requirements of the RTTE directive.
 Notes: - Conformity has been evaluated according to the procedure described in Annex III of the RTTE directive.
 - Receiver class (if applicable): 3.

According to the 1999/519/EC recommendation, minimum distance between the product and the body could be required depending on the module integration.

Warnings: - CE marking applies only to End Products: Because this equipment is only a subassembly, conformity testing has been reduced (equipment has been design in accordance to standards but full testing is impossible). Manufacturer of End Products, based on such a solution, has to insure full conformity to be able to CE label marking.

- As the integration of a radio module requires wireless technological knowledge, ADEUNIS RF proposes its technical proficiency to its customers for a pre-compliance qualification of end products. In case of no-conformity, ADEUNIS RF will not be held back responsible if this stage has not been realised.

Crolles, November 6th, 2007
 VINCENT Hervé / Quality manager

Download of the user guide

Thank you for having chosen the ADEUNIS RF products.

User guides can be uploaded directly on our web site www.adeunis-rf.com

Index **Products**
 Paragraph **OEM Modules > Transceivers**

Print version available upon request

- ✓ Tel : +33 4 76 92 07 77
- ✓ Email : arf@adeunis-rf.com

Presentation

The synchronous NRZ A^{RF29} is a transceiver in the 869 MHz band with a transmission power up to 500mW. This transceiver enables connections to be established over several kilometers.

The synchronous A^{RF29} is available in 2 versions offering different transmission rates / channelling combinations:

- ARF6921Gx: 1 channel at 76.8kbps NRZ (38.4kHz).
- ARF6921Hx: 2 channels at 38.4kbps NRZ (19.2kHz).
-

User's interface

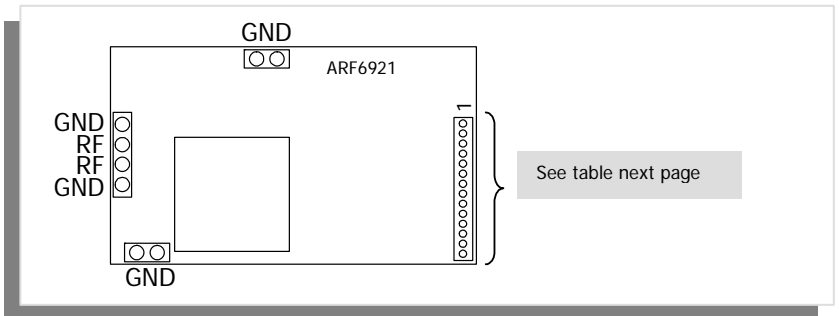

Connectors	Ref. No.	Name	Direction	Function
J1	1, 14	GND	Power supply	
	2	POWER DOWN	Input	Module in standby
	3	BUSY	Output	Indicates when module is not available
	4	TX/RX	Input	Transmitter/Receiver mode selection
	5	P1	Input	Power level selection
	6	DATA	Input/Output	Data to be transmitted in Tx mode/ Data received in Rx mode
	7	P0	Input	Power level selection
	8	VCC	Power supply	Power supply input
	9	C2	Input	Channel selection
	10	CLOCK	Output	Clock recovery for data synchronisation
	11	C1	Input	Unused – Do not force any potential
	12	RSSI	Output	Indicates RF level received
	13	C0	Input	Unused – Do not force any potential
J2	1, 4	GND		
	2, 3	RF		RF output/Module antenna

Power supply

Power supply of this module requires some particular attention.

The synchronous ARF6921 transceiver power supply must be a 3V regulated voltage provided by the motherboard and applied between pin 8 and pins 1 and 14 of the connector.

The power supply source must be able to provide a current of 600 mA. This capacity can be reduced to 30 mA if the module is only used as a receiver.

NOTE

Pay attention to the choice of the power supply: it has to be able to withstand the variations of load due to mode changes (from reception to transmission for example...)

All the module's GND connections must be connected to the motherboard.

Standby

This mode enables to limit the consumption to around 400 μ A.

IMPORTANT: this consumption assumes that the C2, P1 and P2 inputs are OFF. If one of these inputs is activated (ON), the consumption will increase by 130 μ A (260 μ A if two inputs are ON...).

In this mode, the module doesn't receive and supply any information on its outputs.

Power_down = 0V: normal mode

Power_down = VCC: standby mode

Transmit/Receive mode selection

The TX/RX input enables the transceiver to be set to transmission or reception. Switching from one mode to the other is not instantaneous, see the different switching times in paragraph 4.

TX / RX = 0V: module in reception mode

TX / RX = VCC: module in transmission mode

Data to transmit / data received

This module operates **in synchronous NRZ mode**. The frame definition and bit coding/decoding operations are taken in charge by the associated logic.

The data to be transmitted or delivered should be in the form of a digital signal between 0 and VCC. The A^{RF29} module won't process analogic data.

In transmission mode, the module provides data clock at CLOCK pin and DATA pin is used as a data input. Data is clocked into the module at the rising edge of CLOCK. The data is modulated at RF without encoding.

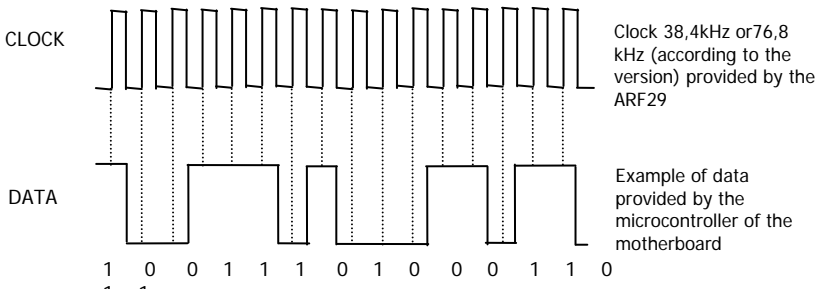

In reception mode, the transceiver performs the synchronisation and provides received data clock at CLOCK pin and demodulated data at DATA pin. The data should be clocked into the interfacing circuit at the rising edge of CLOCK.

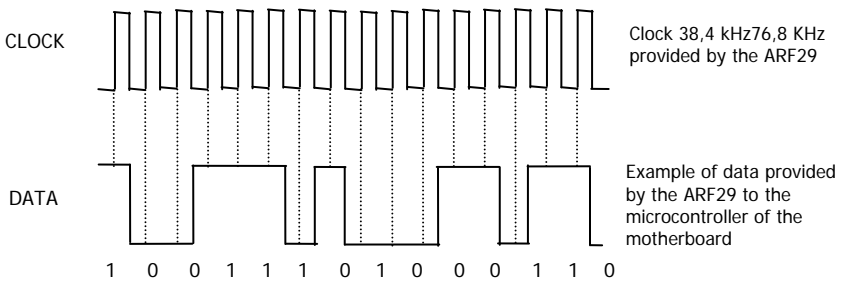

Bit encoding

The Bit Time must be equal to $n/76800$ sec, n is an integer between 1 and 100 (for ARF6921G).

The Bit Time must be equal to $n/38400$ sec, n is an integer between 1 and 100 (for ARF6921H).

In the case of radio transmission, it is preferable to limit the spectrum of the signals, particularly for low frequencies, even if this involves increasing the main frequency. In a frame, the maximum number of consecutive 1 or 0 must be lower or equal to 9.

Frame encoding

Once the bits have been encoded, it is imperative to transmit them according to a frame structure; the radio link is very sensitive to binary flow breaks that can be minimised thanks to byte "serialisation".

A conventional frame structure is set out below :

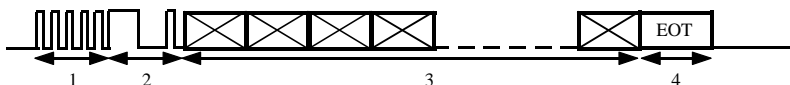

- 1. Preamble :** Electrical succession 101010... designed to fix the receiver polarisation and to compensate the channel settling time.
- 2. Synchronisation word:** Electrical pattern that marks the start of the useful data by a break in the binary flow of the preamble. Recommended synchronisation words are 2 Bytes (D391)hex or 3 bytes (D391DA)hex. The pattern used must be forbidden in the useful part of the frame.
- 3. Useful part:** Successions of bytes encoded at bit level.
- 4. Stop pattern:** Indicates the end of the frame (necessary when the frame length can vary).

In these conditions, the Frame Error Rate (FER) will be around 0.5% (up to 3%). It's possible to significantly reduce this FER by adding few ms of carrier (Continuous 0 or 1) before the preamble.

Channel selection

ARF6921G (single-channel)

There is only one channel available at 869.525 MHz.

For this version, the inputs C0 to C2 must not be forced to any potential (OFF position).

ARF6921H (2-channel)

C2 = OFF (unconnected): frequency 869.4625 MHz.

C2 = ON (grounded): frequency 869.5875 MHz.

The input C2 is sufficient to select the channel, C0 and C1 must not be forced to any potential (OFF position).

Transmitted power selection

The two inputs P0 and P1 enable the transmission power to be adjusted and the consumption to be reduced. These inputs are polarised on the module, they must either be unconnected (**OFF**) or **grounded (ON)**.

P0	P1	Power
ON	ON	+14 dBm (25mW)
ON	OFF	+20dBm (125mW)
OFF	ON	+23 dBm (200mW)
OFF	OFF	+27dBm (500mW)

Only OFF/OFF mode (maximum power) is guaranteed. The levels of the other modes are given for indication purposes only. At each power step, the consumption is about 100mA lower than the higher level.

BUSY output

This output indicates by a level that the module is unavailable to transmit or receive. This occurs momentarily when the module changes a mode (e.g. switching from TX to RX, power-up, standby mode exit, etc.) and when calibrations are performed (recalibrating the VCO).

The duration of the calibrations is < 30 ms.

The data received or transmitted when the BUSY signal is at low level are non-significant or not transmitted.

Switching from transmission / receipt :

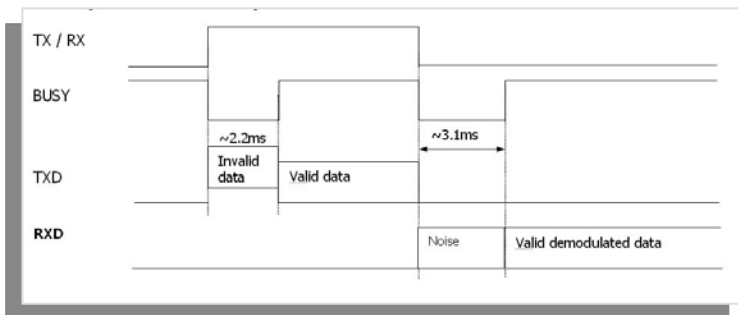

Switching from standby / transmission

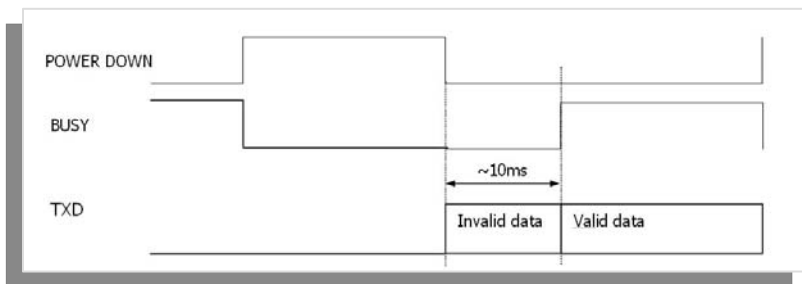

NOTE

The BUSY time can reach up to 28ms
Switching from standby / receipt :

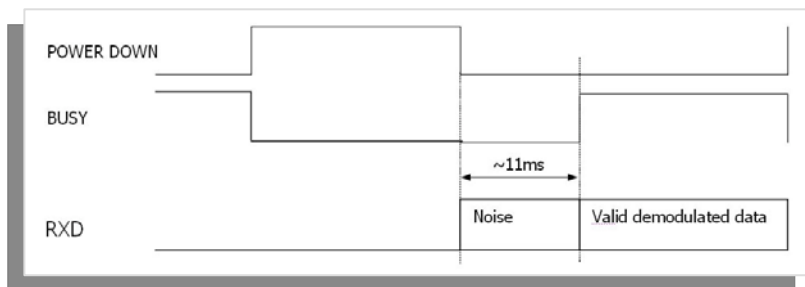
**NOTE**

The BUSY time can reach up to 28ms

Power up :

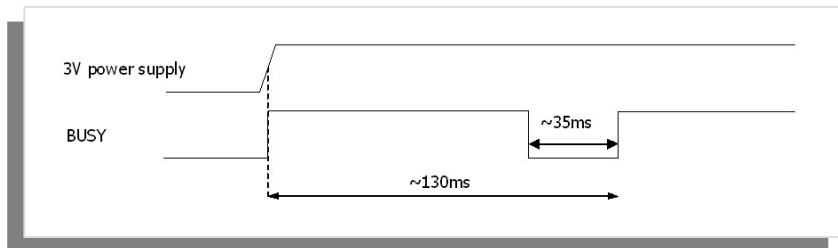
**NOTE**

On power-up :

- The module is unavailable for 130ms. It is therefore necessary to wait until the end of the pulse on the Busy signal to consider the module available.
- **ON START-UP** : The BUSY pin is considered as an input by the module. This pin **MUST** therefore be left OFF on power-up.

Channel settling time (Cst)

This characteristic corresponds to the time required to obtain the first valid bits on receipt on an A^{RF29} #2 (RXD2) on continuous listening after transmission of a frame from another remote A^{RF29} #1 module (TXD1).

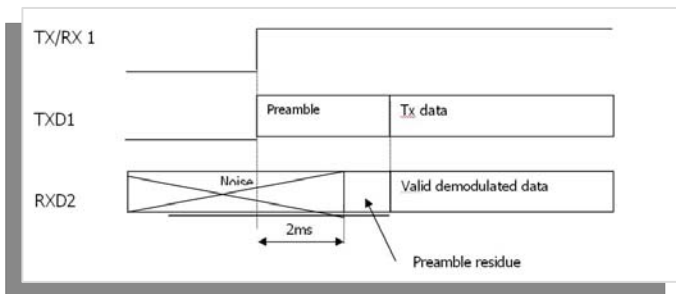

RSSI output

The RSSI signal gives an **indication** of the power received. It is an analogic output whose mean value varies linearly with the power received.

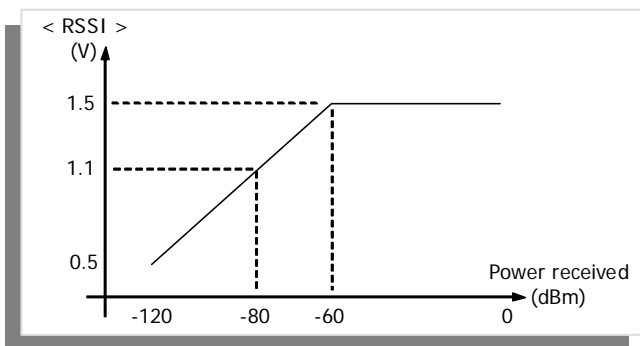

TAKE CARE

- The RSSI information must not be used to wake up the receiver in applications where range and therefore maximum sensitivity are sought.
- The RSSI level remains an indicator which must be used carefully due to dispersions between components.

The curve presented above may therefore be subject to slight changes from one product to another. These dispersions are also strongly linked to the temperature of use of the A^{RF29}.

- The RSSI level can also indicate the presence of a jammer in the channel. Therefore, RSSI can't be used to detect a useful signal sent by a remote transmitter. The identity of the transmitter also has to be checked by analysing the frames received.

RSSI is a necessary but not sufficient condition to achieve correct reception.

Recommandations for use

Mother board :

The signals of the different electrical accesses are described in the chapter related to "user interfaces". The "Low Frequency" pins (connector J1) can be connected on the motherboard through a 1.27mm pitch strip. For the J2, J3 and J4 connectors, 2.54mm pitch strips (HE14 type) must be used.

The antenna output can be located on the motherboard via a 50 Ohm printed line. This line is formed by a 2.5mm wide printed track which must be placed above the continuous ground plane (distance between the HF cold point and ground plane must be as short as possible). Avoid running close to the digital lines!

EMC aspect :

When integrating a radio element in an electronic system, the motherboard must have a ground plane as continuous as possible. The GND signals from the module should be connected as short as possible to this plane. It is preferable for the module to then be mounted on the ground plane side, opposite the tracks.

A receiver without a mute generates output noise in the absence of a receipt signal. This does not mean that it is polluted by a disturber - the data will be "clear" on receipt.

TAKE CARE

The presence of a mobile phone near the receiver may disturb long distance transmissions.

Dimensions

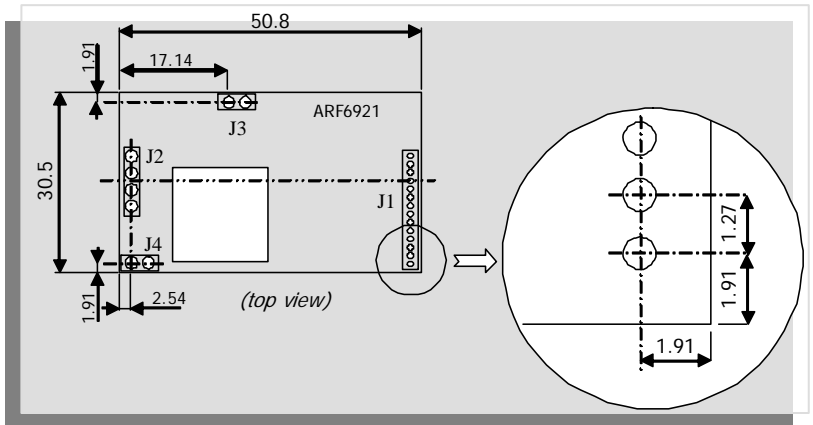

- The dimensions are given in mm.
- The connectors are not supplied with the module.
- J1 has a pitch of 1.27mm and J2, J3 and J4 a pitch of 2.54 mm.

Compliance with regulations

When using radio transceivers in the form of integrated daughter boards, conformity with regulation compliance relates to the finished product.

In Europe, finished products must comply with the RTTE directive. For this type of radio application, conformity with the RTTE directive will be established by compliance with the following requirements :

- EN300220 standard (Efficient use of Radio/spectrum).
- EN301489 standard (EMC).
- EN60950 standard (Electrical safety if necessary)

IMPORTANT

Although the A^{RF29} daughter boards comply with the criteria and dimensions of the EN300220 radio standard, their integration in a “mother” electronic system may modify some electrical characteristics (harmonic levels, spurious RF, etc.)

Before it is sent for laboratory tests, the product therefore has to be examined on our premises to check that it complies with regulations. After presentation, the product and the test reports must be kept as proof of conformity.

Specifications

Transmitter (Tx)

Maximum power	500mW (+27dBm)	In 50 Ohms
Modulation	FSK +/-40kHz FSK +/-20kHz	Version G (1-channel) Version H (2-channel)
Consumption	550 mA	- @max power - in 50 Ohms
Wake-up time	10ms	From Power_Down mode
Rx to Tx turn-around time	2ms	

Receiver (Rx)

Sensitivity	-103 dBm (1.6uV) -105 dBm (1.25uV) For $10^{-3}/\text{PN9}$	Version G (1-channel) Version H (2-channel)
Passband @3dB	60 kHz 40 kHz	Version G (1-channel) Version H (2-channel)
Consumption	25 mA	
Wake-up time	10 ms	From Power_Down mode
Rx to Tx wake-up time	3 ms	

Transceiver (Trx)

VCC power supply	Regulated 3V	
Transmission rate	76,8 kBps NRZ i.e. 38.4kHz 38,4 kBps NRZ i.e. 19.2kHz	G version (1-channel) H version (2-channel)
Digital input/output	0/VCC	
Standby consumption	400µA	Take care over the position of C2, P1 and P2
Channel settling time	2 ms	
Free field range	3 km 4 km	G version (1-channel H version (2-channel))
Temperature	From -20°C to +70°C	
Dimensions	30.5 x 50.8 x 12	in mm
Standards	EN300220 EN301489	Radio EMC

References

ARF6921G : Transceiver – single-channel – transmission rate 76.8 kbps NRZ with clock recovery

ARF6921H : Transceiver – 2-channel – transmission rate 38,4 kbps NRZ with clock recovery