

A^{RF05} Transceivers Modules



User Guide

No part of this document may be reproduced or transmitted (in electronic or paper version, photocopy) without Adeunis RF consent.

This document is subject to change without notice.

All trademarks mentioned in this guide are the property of their respective owner.

ADEUNIS RF
283, rue Louis Néel
38920 Crolles
France

Phone +33 (0)4 76 92 07 77

Fax +33 (0)4 76 08 97 46

Ref. 07-08-V7-pft

Table of Contents

About this Document	2
Declaration of Conformity	3
General use	4
Dimensions – PIN assignments	5
Programming (optional)	6
Programming in "fast transmission" mode	6
Programming in "range attenuation" mode	7
Reset	7
"Power-down" mode	8
Protocol	9
Bit encoding level	9
Frame encoding level	10
Radio channel management	10
RSSI	12
Integration	13
Daughter board	13
EMC aspect	14
Specifications	16

About this Document

This guide describes the A^{RF05} devices, their options and accessories.

Declaration of Conformity



Manufacturer's name
Manufacturer's address

ADEUNIS R.F.
Parc Technologique PRE ROUX IV
283 rue Louis NEEL
38920 CROLLES - FRANCE

declares that the product if used and installed according to the user guide available on our web site www.adeunis-rf.com

Product Name: **ARF05**
Product Number(s): **ARF6899A / ARF6899B / ARF7356A**

is designed to comply with the RTTE Directive 99/5/EC:

EMC: according to the harmonized standard EN 301 489.

Safety: according to the standard EN 60950-1/2001

Radio: according to harmonized standard EN 300-220 covering essential radio requirements of the RTTE directive.

Notes: - Conformity has been evaluated according to the procedure described in Annex III of the RTTE directive.

- Receiver class (if applicable) : 3.

According to the 1999/519/EC recommendation, minimum distance between the product and the body could be required depending on the module integration.

Warnings: - CE marking applies only to End Products: Because this equipment is only a subassembly, conformity testing has been reduced (equipment has been design in accordance to standards but full testing is impossible). Manufacturer of End Products, based on such a solution, has to insure full conformity to be able to CE label marking.

- As the integration of a radio module requires wireless technological knowledge, ADEUNIS RF proposes its technical proficiency to its customers for a pre-compliance qualification of end products. In case of no-conformity, ADEUNIS RF will not be held back responsible if this stage has not been realised.

Crolles, November 6th, 2007
VINCENT Hervé / Quality manager

Download of the user guide

Thank you for having chosen the ADEUNIS RF products.

User guides can be uploaded directly on our web site www.adeunis-rf.com

Index **Products**

Paragraph **OEM Modules > Transceivers**

Print version available upon request

✓ Tel : +33 4 76 92 07 77

✓ Email : arf@adeunis-rf.com

Ref. 07-08-V7-pft

General use

The A^{RF05} radio module is a single-channel FSK transceiver for digital RF transmission using the 433.05-434.79 MHz waveband, the 869.4-869.65 MHz waveband or the 902-928 MHz waveband.

It enables two-directional half-duplex digital links to be achieved with a transmission rate up to 40KBps in Manchester encoding.

The A^{RF05} develops a power about 12 mW on 50 Ω in transmission mode.

The radiated powers are then about 10mW when a 17-cm whip antenna is used with 433,92 MHz transceiver or 8 mW when a 8-cm whip antenna is used with 869,525 MHz (915 MHz) transceiver.

This transmitter is compatible with any wideband FM receiver accepting a frequency deviation of +/- 50 kHz.

In receipt mode, the sensitivity is better than 1.25 μ V for 12 dB SINAD (about 10-2 BER) i.e. -105dBm.

The receiver is compatible with any transmitter that respects these bandwidths and deviations (consult us if a transmitter other than the A^{RF05} is used).

The A^{RF05} transceiver is composed of "raw" radio components, the transmission protocol (data encoding/decoding) and programming of the radio module has to be performed by the associated logical unit.

The use of a whip antenna is compulsory to obtain good performances, a slight shortening is however possible. (Consult us).

NOTE

(*) Take care! Switching to fast mode results in a loss of about 6dB sensitivity. This mode must therefore only be used for applications requiring a transmission rate higher than 12kbps Manchester.

Programming in "range attenuation" mode

The transmission power and receipt sensitivity of the A^{RF05} modules can be attenuated by programming (see table below). This mode enables minimising the consumption on the transmitter and/or receiver side for short-range applications running on battery.

Transmission rate	Word to be sent 24 bits
Transmission power attenuation (*)	(0004F8)hex
Receipt sensitivity reduction (about 5dB)	(0004E9)hex
Return to default mode (no attenuation)	(0004F9)hex or RESET

NOTE

Take care! Attenuation depends on the operating voltage of the module. From about 4dB in 5V, it amounts to about 12dB at 3V.

Reset

The module is provided with an automatic reset system on power-up of the module (reset registers), it is therefore not necessary to connect this pin to the VDC potential (integrated pull-up).

Automatic reset on power-up takes about 300ms, no frames and no serial data should be sent during this period.

This time is identical in case of an external action on the RESET/ pin.

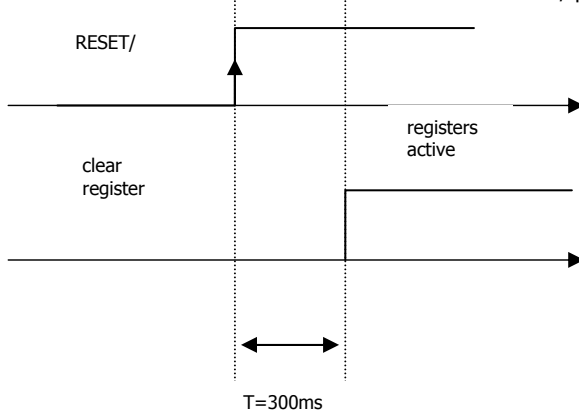

“Power-down” mode

Enables the product to be sampled via the PWRDN pin (transceiver valid if PWRDN = 0 / standby if PWRDN = 1).

If a pull-down resistor is used, it must be less than 220 Ohms! !

TAKE CARE! On standby (PWRDN = 1), pin 4 (RxTx) must be pulled to 0 and the 3-wire bus (DATA/CLOCK/EN) be left on high impedance.

NOTE

In case of switching to standby after power-up, the timing diagram below must be respected to integrate automatic reset.

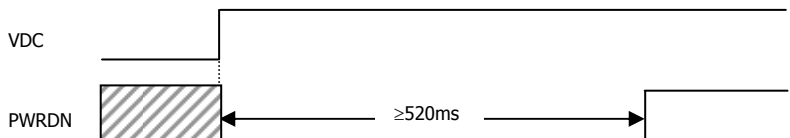

Protocol

The modulating signals (DATA IN-OUT pin) must have a frequency between 0.2KHz and 12KHz (default mode) or 0.2KHz and 40kHz (extended – fast transmission mode).

Frequencies lower and higher than this band cannot be transmitted. This means that the link cannot transmit constant states having a duration longer than 500 μ s.

Bit encoding level

Most conventional hardwired serial links transmit bytes asynchronously using an NRZ encoding (1 logic bit = 1 electrical state). As a result, the spectrum occupation of the signals generated this way is about one decade. Furthermore, sampling of the bytes received this way assumes perfect synchronisation of decoding on the start bit.

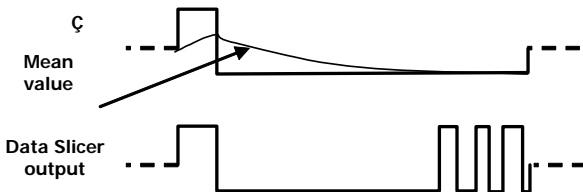

In case of radio transmission, you'd better limit the spectrum of the signals to be transmitted as much as possible, particularly for low frequencies, even if this involves increasing the main frequency. Moreover, you'd better have the synchro reset on each transmitted bit; receivers are in fact the cause of large duty cycle errors on the electrical states.

The following bit encoding should therefore be preferred:

Manchester or two-phase :

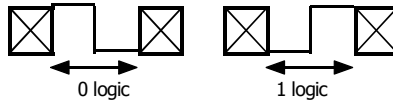

Frame encoding level

Once the bits have been encoded, they must then be transmitted according to a frame structure; the radio link is very sensitive to binary flow breaks which can only be minimised by "serialising" the bytes.

A conventional frame structure is set out below :

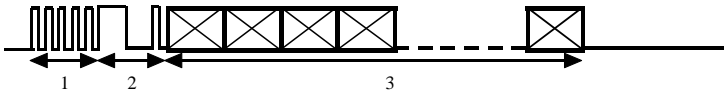

Preamble : Electrical succession 101010... to set the receiver polarisations and compensate the channel settling time.

Sync. pattern: Electrical pattern marking the start of the useful data by a break in the binary flow of the preamble.

Useful part: Succession of bytes encoded at bit level.

Radio channel management

Radio channel settling

This feature corresponds to the time required to obtain the first valid bits on receipt on an A^{RF05} #2 (DATA IN-OUT 2) after transmission of a frame from another remote A^{RF05} #1 module (DATA IN-OUT 1).

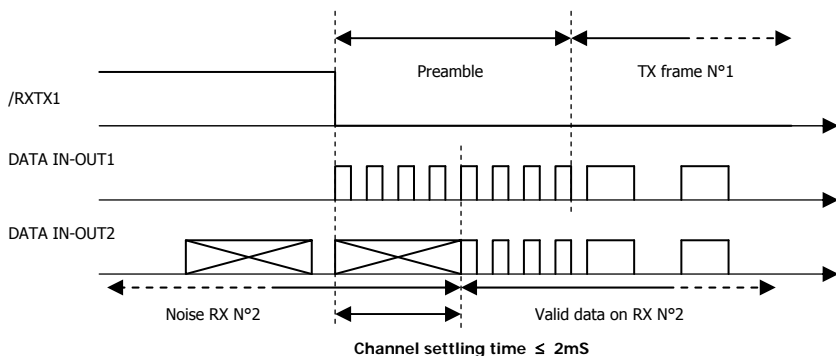

Wake-up time (Starting time)

This feature corresponds to the time required to switch from Stand-by mode (low consumption) to 'active' mode (TX or RX).

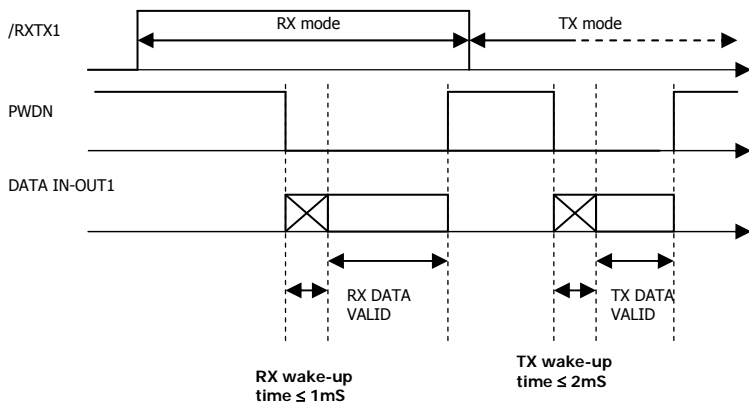

Transceiver turn-around

This feature corresponds to the time required to switch from valid transmission to valid receipt or vice-versa on the same piece of equipment, and therefore to a change of state of the control input TX_RX.

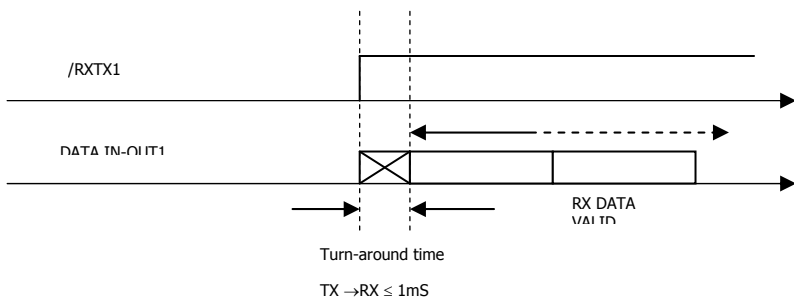

RSSI

The graph above (VDC=3V) gives a correspondence between the value of the RSSI and the received power level.

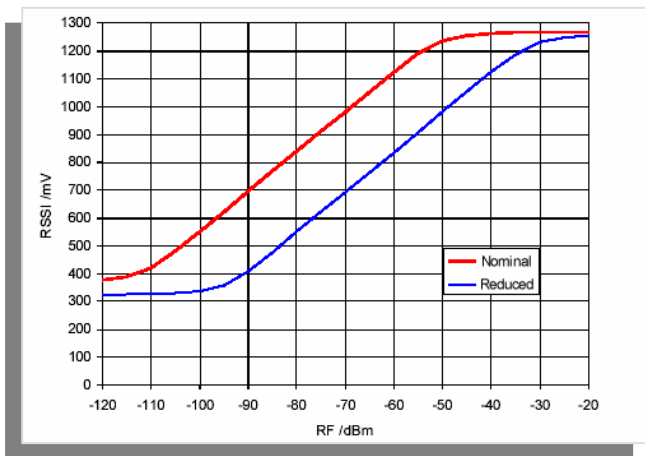

BEWARE

The RSSI level remains an indicator that has to be used with precaution due to the important dispersions between ICs. The curve presented above may therefore undergo slight variations from one product to another. These dispersions are also greatly dependent on the operating temperature of the A^{RF05}.

The RSSI level may also indicate the presence of a jammer in the channel used. Therefore, examining the RSSI alone is no guarantee of good detection of a useful signal from a remote transmitter. The identity of the transmitter also has to be ensured by analysing the frames received. RSSI is a necessary but not sufficient condition to get a correct receipt.

Integration

Daughter board

The interface with the mother board has to be achieved through copper pads on both PCB sides. No component can be located under the module when using SMD mounting (see the following footprint).

The daughter board ARF6899B can be fitted directly in a motherboard electronic system by means of "COMCLIP" connectors mounted on the radio module (see dimensions and pin assignments).

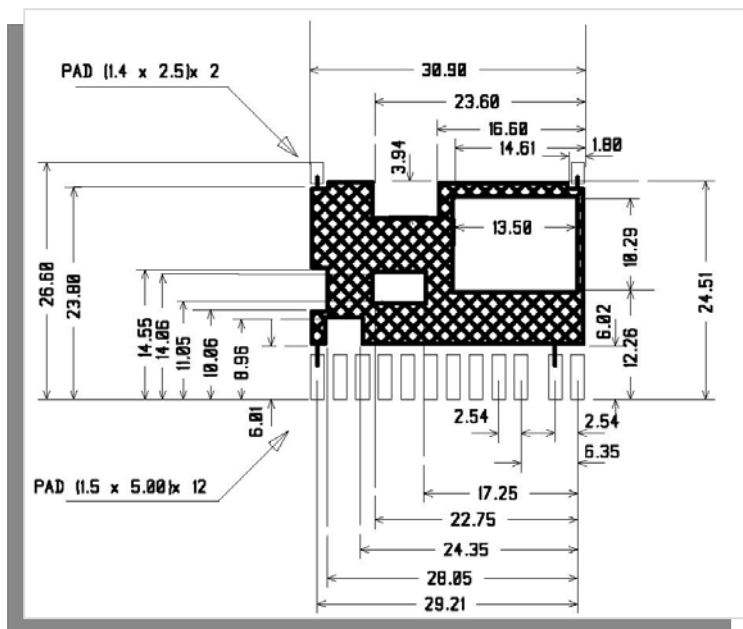

Recommended footprint for SMD integration (dimensions in millimetres)

The mother board can be used to transfer the antenna output by means of a 50Ω microstrip line. This line is formed by a 2.5mm-wide printed track (for 1.6 mm FR4) which must be located above a continuous ground plane (the HF cold point is to be connected as close as possible to this plane). Avoid running close to a digital path!

EMC aspect

When integrating a radio element in an electronic system, the mother board has to be provided with a ground plane as continuous as possible.

The GND and GND RF signals of the module are to be connected as close as possible to this plane. This module should be fitted on the ground plane side, opposite from the tracks.

Due to the presence of a receipt part (for the transceiver), pay attention when integrating the A^{RF05} module. Incorporating a receiver of good sensitivity alongside a high-speed digital part requires a succinct power supply filtering as described below :

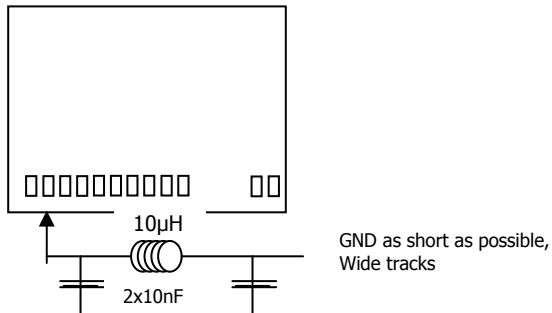

NOTE

A receiver without squelch generates noise on output in the absence of a receipt signal. This does not mean in any way that it is polluted by interference; the data will be "clear" when receipt takes place.

Specifications

	433.92 MHz	869.525 MHz (915 MHz)
Transmitter		
Frequencies	433.92MHz	869.525MHz (915 MHz)
Power developed (/ 50 ohms) @ 3V	8 dBm	6 dBm
Power developed (/ 50 ohms) @ 5V	12dBm	10dBm
Modulation	2FSK+-50kHz	2FSK+-50kHz
Current consumption @ 3V	15mA	15mA
Current consumption @ 5V	20mA	20mA
Receiver		
Technology	Homodyne	Homodyne
Frequencies	433.92MHz	869.525MHz (915 MHz)
Sensitivity (to S/N)	1.25 μ v (-105dBm for 10-3/PN9)	1.25 μ v (-105dBm for 10-3/PN9)
Demodulation	2FSK+-50kHz	2FSK+-50kHz
Bandwidth	2MHz front end, 150kHz back end	2MHz front end, 150kHz back end
Digital output	0/VCC	0/VCC
Current consumption @ 3V	14mA	14mA
Current consumption @ 5V	17mA	17mA

	433.92 MHz	869.525 MHz (915 MHz)
Transceiver		
Operating voltage	From 2.1 to 5.5V	From 2.1 to 5.5V
Standby current	<1uA	<1uA
Transmission rate	0.2kHz-12kHz (standard mode) 0.2kHz-40kHz (extended mode)	0.2kHz-12kHz (standard mode) 0.2kHz-40kHz (extended mode)
Transmitter wake-up time	≤2mS	≤2mS
Receiver wake-up time	≤1mS	≤1mS
TX to RX turn-around time	≤1mS	≤1mS
RX to TX turn-around time	≤1mS	≤1mS
Channel settling time	≤2mS	≤2mS
Operating temperature	-20°C to +70°C	-20°C to +70°C

References

- ARF6899A : Transceiver 433.92 MHz SMD version**
- ARF 6899B : Transceiver 433.92 MHz COMCLIP version**
- ARF 7356A : Transceiver 869.525 MHz SMD version**
- ARF 7356B : Transceiver 915 MHz SMD version**